

Kerbing & Islands

Cycleways

Traffic Calming

Passive Safety

Site Safety

Inclusive Mobility

Installation

Kerbing & Islands

Cycleways

Traffic Calming

Passive Safety

Site Safety

Inclusive Mobility

Installation



REDIWELD

Traffic
Products





Hello Welcome to Rediweld!

We pride ourselves on the use of recycled materials and the green innovation that creates sustainable products.

For our customers, some of the greatest benefits come from the ease and speed of installation. This minimises disruption and the use of traffic management, which reduces the risk for highway operatives.

No excavation is required and products can be relocated. These are cost benefits that help stretch limited budgets and deliver more for less.

Roger Marsh Managing Director



“ Rediweld has a wealth of experience in both the design and manufacture of traffic products. We are also committed to reducing waste and energy consumption. In addition of supplying our own products we work with customers to produce their own bespoke products.”



We Offer Complete Solutions!

Rediweld can offer the complete package from site survey to product maintenance.

With all their application knowledge, our Sales team can handle your enquiry and be a point of contact to coordinate manufacturing and installation.

As standard we provide Chapter 8 'Give & Take' and use our own in house team for installation.



Our Products & Services !

Contents Page



SUSTAINABILITY

Pg 4 - 5 Green Innovation
Pg 6 Complete Package
Pg 7 Custom Moulding



KERBING & ISLANDS

Pg 8 - 9 Traffic Islands
Pg 10 - 11 Splitter Islands
Pg 12 - 13 Surface Kerbing



CYCLEWAYS

Pg 14 -17 Cycle Segregation



TRAFFIC CALMING

Pg 18 - 21 Speed Cushions
Pg 22 - 23 Raised Tables



PASSIVE SAFETY

Pg 24 - 27 Pole Cones



SITE SAFETY

Pg 28 - 31 Vehicle Stoppers
Pg 32 - 33 Speed Ramps



INCLUSIVE MOBILITY

Pg 34 - 35 Tactile Surfaces
Pg 36 Level Access
Pg 37 Bus Ramp



INSTALLATION

Pg 38 - 39 Installation Support

Why Choose Us?

Rediweld can offer a complete package from enquiry to installation, across a wide range of highway and safety products.

- ✓ SITE SURVEYS
- ✓ EASE OF INSTALLATION
- ✓ MINIMUM DISRUPTION
- ✓ NO EXCAVATION
- ✓ CONSISTENT PROFILES
- ✓ SURFACE MOUNTED
- ✓ MANUAL HANDLING
- ✓ RECYCLED MATERIAL
- ✓ MADE IN THE UK
- ✓ RELOCATABLE
- ✓ IN HOUSE INSTALLATION
- ✓ MODULAR DESIGN



Truck tyre recycling



Quality Supply Chain from retreading to grading and packing to create a consistent material with durable properties

Rediweld
Green Innovation



High quality rubber from retreading truck tyres

Grading and Sieving



Grading & Packaging



Low temperature bonding



- Minimal Material Waste
- Reduced Environmental Impact
- Low Carbon Footprint
- No Spoil
- End of Life Recycling
- Creating UK Jobs



Flexible Ergonomical Production
Optimum Floor Space Utilisation
Processing 250kg/hour



Kitting up each order



Rediweld The Complete Package

Nobody knows our products better than our Sales staff and Installation team. Rediweld can offer the complete package from Site Surveys to maintaining our products year after year. Here is a step by step guide to show you how it works.



Rediweld offers a comprehensive Site Survey and will recommend products to suit each scheme.



Once your order is placed the products are manufactured or taken from stock



After the site survey a quotation is raised by the sales office with product information.



From placing of your order to the installation this is coordinated in our Sales office with a point of contact.





By planning and providing the right equipment products are installed quickly with minimum disruption.



Installation is always arranged to suit the customer requirements. We offer as standard Chapter 8 'Give & Take' However, we can also provide 'Stop and Go' or temporary traffic signals.

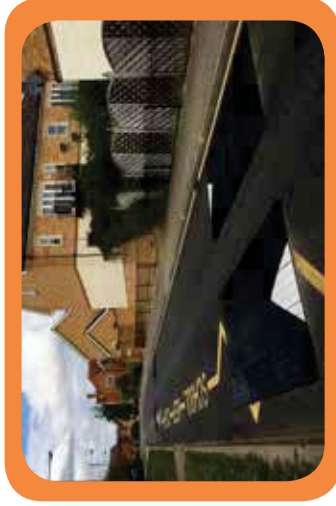

Products are then picked and shipped to customers.

Rediweld offers a maintenance scheme to suit your requirements.



Rediweld Custom Moulding

We also manufacture products to Customer Specifications.

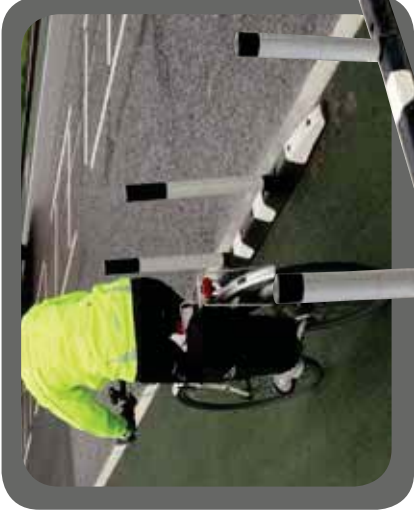

Greenwich Wand Orca

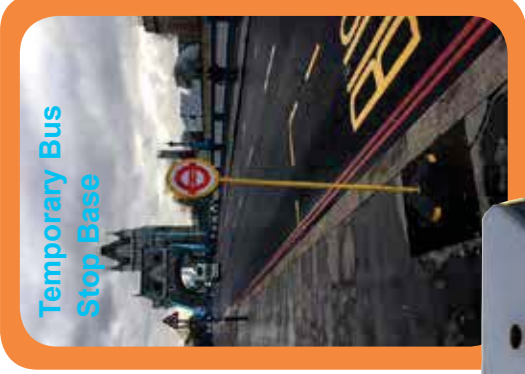

Temporary Bus Stop Base



Bus Stop Bumper Foot

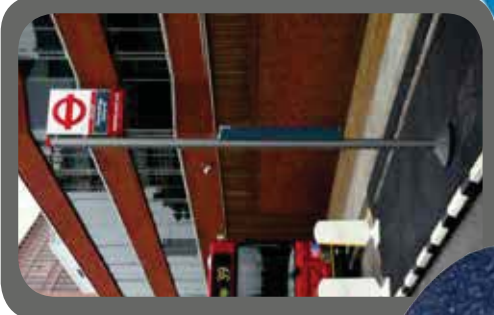

RediPave Traffic Islands

RediPave is a comprehensive range of Surface Mounted Islands with a Half Battered face profile.



RediPave Edge Module
500mm wide x 500mm long
125mm high
21.7kg weight



RediPave Radius Module
500mm wide x 500mm long
125mm high
14.0kg weight



RediPave Corner Module
500mm wide x 500mm long
125mm high
21.9kg weight



RediPave Centre Module
500mm wide x 500mm long
125mm high
21.5kg weight

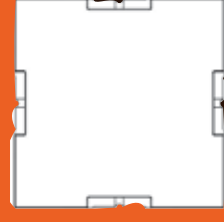

Complete System

Manually handled with no infill required and relocatable

Easy Installation

Installed in less than one hour reducing risk to operatives

Minimum Disruption

To users and the public

Surface Mounted

Bolt down with no excavation and no spoil

Environment

Recycled product made in the UK

Traffic Lights or Posts

Islands can be incorporated with Sign Posts or Traffic Lights to suit



Rediweld Traffic Islands provide an ideal way of creating Islands with minimum disruption.

The standard RediPave colour is black but they are also available in grey and 'granite' grey with white or yellow markings.

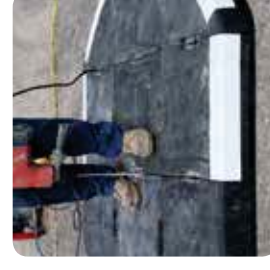
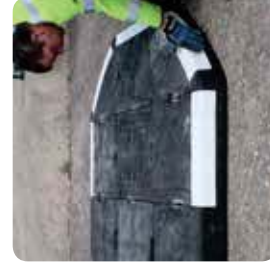

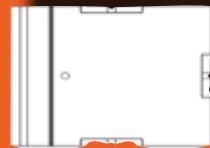

Kerbing & Islands

RediPave Bull Nose Module
700mm wide x 400mm long
125mm high
14.0kg weight

RediPave Left Hand Side Module
500mm wide x 600mm long
125mm high
16.0kg weight

RediPave Right Hand Side Module
500mm wide x 600mm long
125mm high
16.0kg weight

RediPave Edge Module
200mm wide x 500mm long
125mm high
8.80kg weight

RediPave Centre Module
200mm wide x 500mm long
125mm high
8.80kg weight



Epping



Rediweid provides a wide range of sign bollards to suit customers requirements including solar powered signs.

Fixings for RediPave Traffic and Splitter Islands



Kensington & Chelsea



RediPave Splitter Islands



Kingston



Norfolk

- Complete System Manually handled with no infill required and relocatable
- Easy Installation Installed in less than one hour reducing risk to operatives
- Minimum Disruption To users and the public
- Surface Mounted Bolt down with no excavation and no spoil
- Environment Recycled product made in the UK
- Traffic Lights or Posts Islands can be incorporated with Pole Cones, Sign Posts or Bollards to suit.



Greenwich



RediPave 500mm Splitter Islands

End Module
500mm wide x 250mm long
125mm high
14.0kg weight

Centre Module
500mm wide x 500mm long
125mm high
21.7kg weight

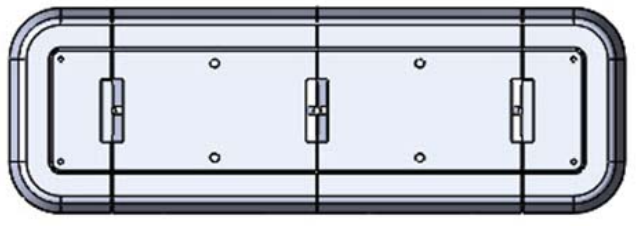
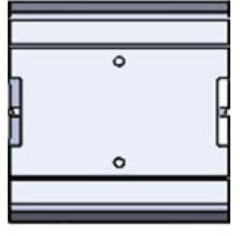
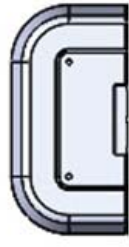

RediPave 400mm Splitter Islands

End Module
400mm wide x 500mm long
125mm high
17.0kg weight

Centre Module
400mm wide x 500mm long
125mm high
19.0kg weight

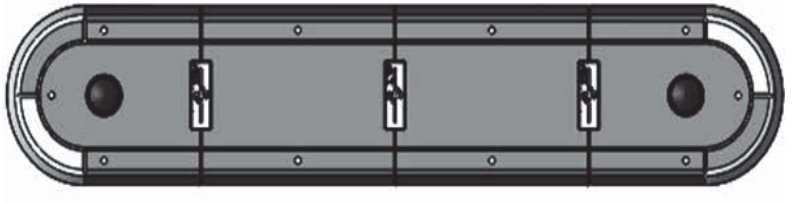

RediPave Splitter Islands have a Half Battered face

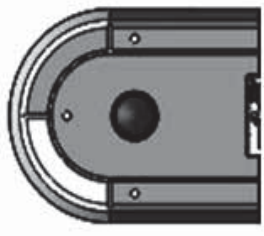

Jislon Satellite & Milestone Islands



Headley, Hampshire



Blackheath, Greenwich



**Jislon Milestone
250mm wide**

End Module
250mm wide x 1000mm long
80mm high
16kg weight
Spayed face

2 x halves make an Island
250mm wide x 2000mm long

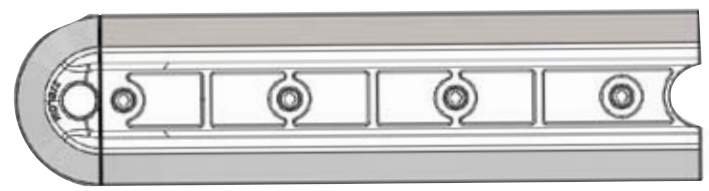

For extra visibility Milestone comes with a reflective light dome at either end and with the option of one in the middle.

Can also be used with the Jislon Pole with the Jislon Pole Cone 80mm or 130mm version.

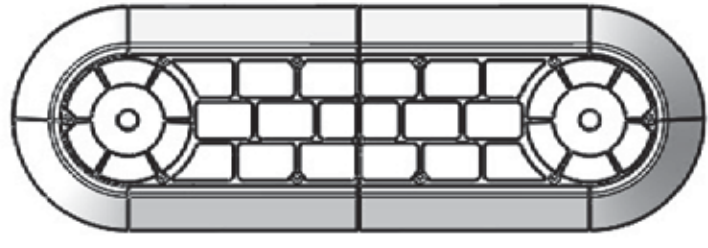

**Jislon Satellite
Island 600mm wide**

End Module
600mm wide x 900mm long
128mm high
42kg weight
Spayed face

2 x halves make an Island
600mm wide x 1800mm long

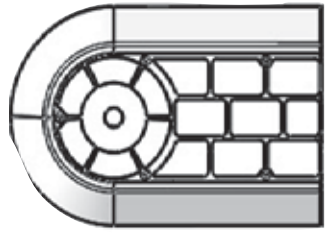

RediKerb SP Surface Kerbing

RediKerb is a comprehensive range of surface kerbing in both half battered (HB) and splayed face (SP) profiles. Kerbs are available in one metre lengths with matching corner units. As standard RediKerb is colour black with white markings. Available also in colour grey, granite or red with the option of no markings.

RediKerb is flexible and can be formed in a curve with minimum radius 4m (SP) and 6m (HB). We also offer a non-flexible Harlow Kerb with HB profile.

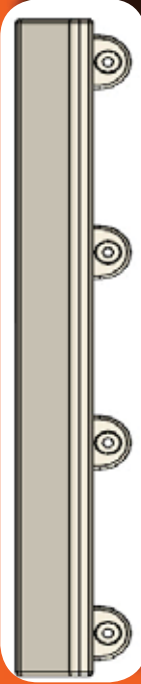

RediKerb SP Straight
150mm wide x 1000mm long
125mm High
10.5kg Weight
4 Fixings



RediKerb SP 180 degree
Corner Unit
250mm Radius
125mm high
7.7kg weight
4 Fixings

RediKerb SP 135 degree
Corner Unit
250mm Radius
125mm high
5.8kg weight
3 Fixings



RediKerb SP 90 degree
Corner Unit
250mm Radius
125mm high
3.9kg weight
2 Fixings

RediKerb SP 45 degree
Corner Unit
250mm Radius
125mm high
2.0kg weight
1 Fixing

Easy Installation

Bolt down product requiring no excavation

Health & Safety

Weight less than 20kg for manual handling

Applications

For multiple or temporary use, can be used on tarmac or concrete surfaces

Environment

Recycled product made in the UK



Enfield



Jersey

RediKerb HB Surface Kerbing

RediKerb HB Straight
150mm wide x 1000mm long
125mm High
11.5kg Weight

Southampton, Hampshire



Hen Goed, Caerphilly



Nottingham



RediKerb HB 90 degree
Corner Unit
250mm Radius
125mm high
4.5kg weight
2 Fixings

RediKerb HB 45 degree
Corner Unit
250mm Radius
125mm high
2.3kg weight
1 Fixing



RediKerb HB 180 degree
Corner Unit
250mm Radius
125mm high
8.9kg weight
4 Fixings

RediKerb HB 135 degree
Corner Unit
250mm Radius
125mm high
6.7kg weight
3 Fixings

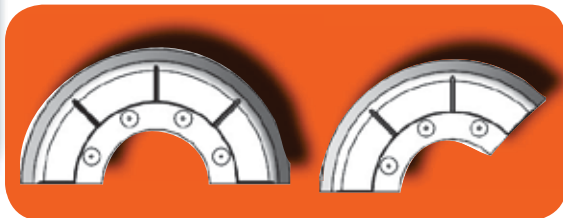

Harlow Kerbing

Harlow Kerb provides a Half Battered profile that is higher than RediKerb but still surface mounted



Harlow Kerb Straight
150mm wide x 914mm long
150mm high
19.0kg weight
3 Fixings

No Corner units available. If you need to form an Island then you will need to mitre the Harlow Kerb accordingly



Cycle Segregation

The Orca is designed to provide light segregation and protection for cyclists as a stand alone product. The Orca should be placed within the cycle lane and positioned up to the white marking which highlights the edge of the carriageway.

The product is classed as street furniture and are neither road signs or road markings. They must not sit on the white line otherwise this will conflict with current TSRGD guidelines.

Typical spacings are from 2.5m up to 10m depending on the application and location. A key feature is that the Orca products are made from recycled rubber, which is durable and will absorb energy on impact without cracking or fracturing, unlike some alternative materials which might cause a puncture on a vehicle or cycle tyre.



Waltham Forest



Croydon



Brent

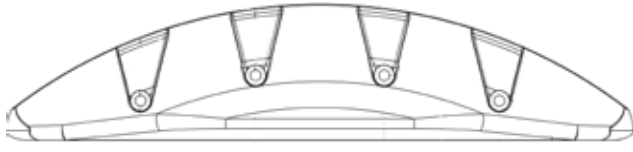

Orca

200mm wide x 920mm long
100mm high
6.5kg weight

Markings

Zig Zag
Tip Toe

Colours

Black
Granite

Fixings

4 x Unique Rediweld fixing system

Zig Zag



Tip Toe



Assymetric Profile

HB face on vehicle side and concave 'cycle friendly' face on kerb side

Design Features

Intuitive interaction with cyclists, drivers, motorists and pedestrians

Safety Benefits

Recycled rubber is tough but safer on impact, reducing risk of injury

Health & Safety

Suitable for manual handling with no mechanical lifting required

Easy Installation

Surface mounted minimising disruption with no spoil and reduced exposure to risk

Re-locatable

To 'future proof' against changes in highway layout and width of cycle lane

Markings Fixing

High visibility markings
Unique fixing with Stainless Steel Coach screw, washer and super tough nylon plug, make for a durable product



The **Mini Orca** Cycle Lane Separator is designed with a low profile to provide light segregation where you require vehicles access, unloading locations, private driveways and junctions. These can be used in conjunction with the other Orca cycle lane products by providing standalone light segregation.

The **Mini Orca** is 50mm high, 720mm long, 120mm wide so can easily be driven over without any obstruction for vehicular access when needed on a particular location, but still providing a clear distinctive cycle lane boundary.

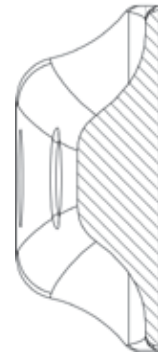

Mini Orca
120mm wide x 720mm long
50mm high
3.0kg weight

Colours
Black
Granite

Fixings
4 x Unique Rediweld fixing system

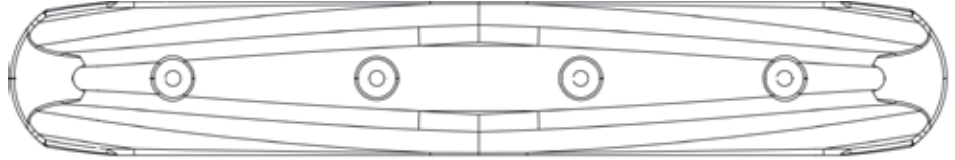

Enfield



London



Enfield



Cycle Segregation

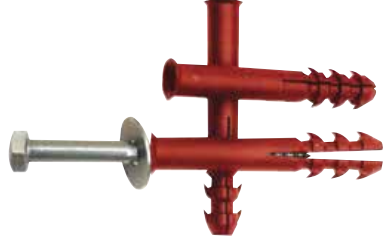

The **Mini Orca** is made from recycled rubber, which is durable and will absorb energy on impact without cracking or fracturing, unlike some alternative materials which might cause a puncture on a vehicle or cycle tyre;

Design Features

Low profile to allow vehicular access if required, but still demarking cycle lane

Safety Benefits

Recycled rubber is tough but safer on impact, reducing risk of injury

Health & Safety

3kg weight suitable for manual handling

Easy Installation

Surface mounted minimising disruption with no spoil and reduced exposure to risk

Cycle Segregation

Cycle Wand Orca

The **Greenwich Wand Orca** offers vertical and horizontal measures intergrated into one product.

The **Greenwich Wand Orca** combines vertical Jislon Pole Cones (Wands) with reflective TSRGD markings, with horizontal rubber modules. This is ideal for segregation over longer distances where vehicle speeds may be higher.

A rubber bung with a reflective glass dome can be used instead of a Jislon Pole Cone.

Spacings for the **Greenwich Wand Orca** will depend on the location and application but typically 5m to 25m however, they can be spaced to allow for cleaning vehicles to access the cycle lane.

Jislon Pole Cones are available in 800mm or 1000mm heights, colour black with TSRGD reflective banding and come with an NSE fixing for quick installation.

The **Greenwich Wand Orca** has 175mm wide and 80mm high modules, Middle (1000mm long, 10.5kg) and End (750mm long, 7.0kg) with moulded in markings, clamped around the base of the Pole Cones or reflective dome for added protection.



Greenwich

Greenwich Wand Orca End Section
175mm wide x 750mm long
80mm high
7.0kg weight
3 Fixings



Gloucestershire

Greenwich Wand Orca Middle Section
175mm wide x 1000mm long
80mm high
10.5kg weight
4 Fixings

London



Design Features

Innovative design to provide horizontal and vertical segregation measures

Manufactured from recycled rubber providing a tough product, safer on impact, reducing risk of injury

Can be used as short or long lengths depending on application

Surface mounted minimising disruption with no spoil and reduced exposure to risk

To 'future proof' against changes in highway layout and width of cycle lane

High visibility markings, EN12899 Certified for Jislon Pole Cones

Unique fixing with Stainless Steel Coach screw, washer and super tough nylon plug, make for a durable product

Safety Benefits

Health & Safety

Easy Installation

Re-locatable

Markings

Fixing

Cycle Segregation

The **Kerb Orca** provides a horizontal measure 100mm high and has a unique design with a SP (Splayed Face) for the cycle side and a HB (Half Battered) profile for the vehicle side. This provides a clear delineation with cyclist and traffic along a cycle lane and can be adjusted in length to suit location.

Being only 150mm wide the Kerb Orca is ideal for narrow roads.

Design Features

Innovative design to provide horizontal segregation measures

Manufactured from recycled rubber providing a tough product, safer on impact, reducing risk of injury
Can be used as short or long lengths depending on application

Surface mounted minimising disruption with no spoil and reduced exposure to risk

To 'future proof' against changes in highway layout and width of cycle lane

High visibility markings

Unique fixing with Stainless Steel Coach screw, washer and super tough nylon plug, make for a durable product

Safety Benefits

Health & Safety

Easy Installation

Re-locatable

Markings Fixing



Gwynedd



Salford



Kerb Orca LH End Section
150mm wide x 1000mm long
100mm high
9.0kg weight
4 Fixings



Kerb Orca RH End Section
150mm wide x 1000mm long
100mm high
9.0kg weight
4 Fixings



Kerb Orca Middle Section
150mm wide x 1000mm long
100mm high
11.0kg weight
4 Fixings



Trafficop Speed Cushions

Cushion Height 65mm or 75mm High Options

Trafficop Speed cushions remain a most effective method of reducing vehicle speeds and so reducing accidents. However, to address the needs of different road users (residents, pedestrians, emergency services, bus operators, cyclists etc...) requires engineered solutions. Drawing on many years of experience, Rediweid has developed its cushions so that they meet the highway engineers exact specification.

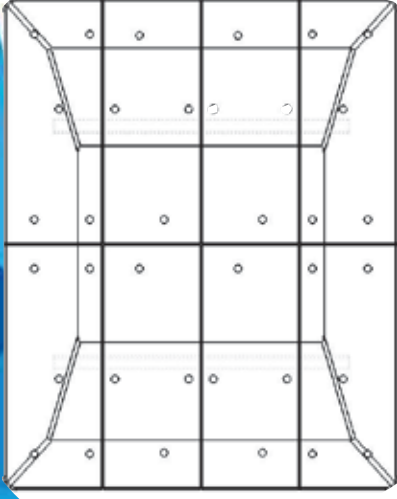

1.6m wide, 2.0m long, 65mm high

Cushion Width Options

1600mm

1700mm

1800mm

1900mm

Cushion Length Options

2000mm

3000mm

4000mm



Wrexham



Bournemouth



Milton Keynes

Proven

Patented design with 40,000 supplied worldwide

Consistent

Preformed construction for consistent profile with fine leading edge that conforms with road camber

Convenient

Quick to install and can be immediately trafficked

Durable

High visibility markings, steel reinforcing and stainless steel fixings. If damaged, modules can be replaced

Versatile

Design allowing different widths, lengths and heights

Surface Mounted

No excavation or adhesive means no spoil and relocatable

Environment

Recycled product made in the UK

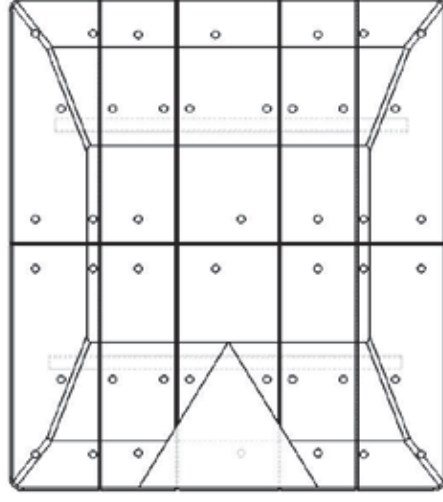

1.7m wide, 2.0m long, 75mm high

Traficop Speed Cushions

Cushion Heights

Traficop was originally developed 75mm high conforming with DfT recommendations. The 65mm version was produced for France and Belgium. This style is now used increasingly in the UK and with a shallower side gradient it is more acceptable to emergency services and bus operators. It also reduces the risk of vehicles grounding on severe cambers.

EXPORT CUSHIONS AND MARKINGS

Traficop Speed Cushions are supplied across Europe and the USA. Each country has its own style of markings, but with Rediweld's moulded in markings the different requirements can be met.



Enfield



Enfield

Customer Feedback:

"We have installed hundreds of Rediweld Traficop Speed cushions in the borough since 2012 and in recent years have used the Belgium Markings which are cushions with the white edgings already included into the cushion design."

"We have found that this significantly decreases the time in which a scheme can be completed as the lining work is minimised and the traffic management is reduced and so cuts down on disruption."

Enfield Council



York City



Sainsbury's, Alton, Hampshire



FRANCE



FRANCE



BELGIUM



HOLLAND

Traficop Speed Cushions

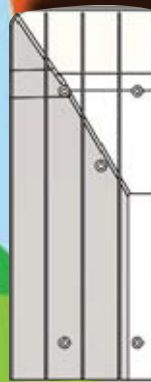

Traficop RH Corner Module
350/400mm wide x 1000mm long
75/65mm high



Traficop Ramp Module
300/400mm wide x 1000mm long
75/65mm high



Traficop Intermediate Module
300/400mm wide x 1000mm long
75/65mm high

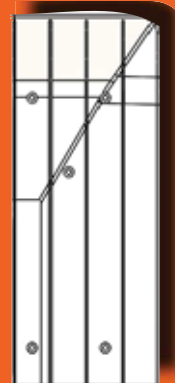

Traficop LH Corner Module
350/400mm wide x 1000mm long
75/65mm high



Traficop Side Module
350/400mm wide x 1000mm long
75/65mm high

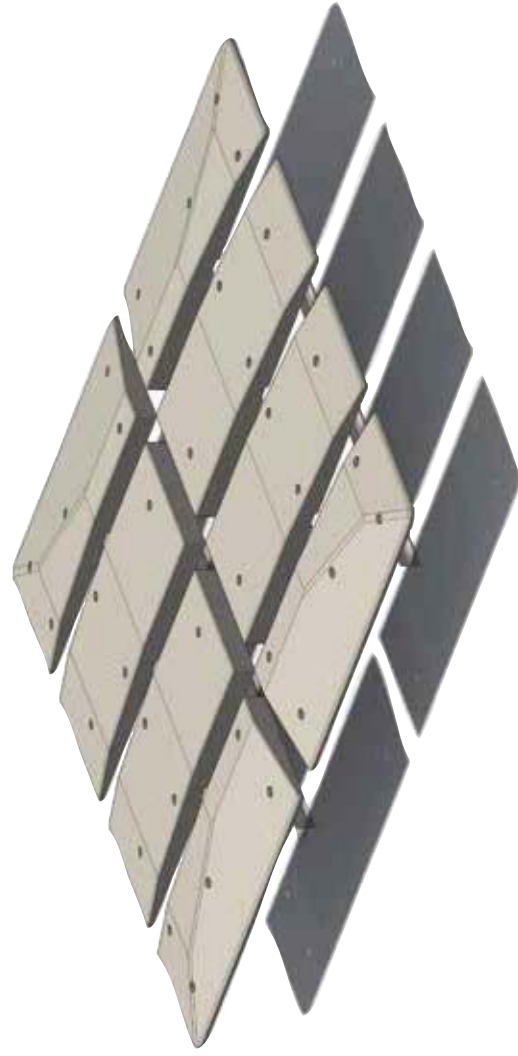

Module	Length (mm)	65mm high Width (mm)	Weight (kg)	75mm high Width (mm)	Weight (kg)
Ramp 300	1000	300	17.0	300	19.0
Ramp 400	1000	400	23.0	400	26.0
Intermediate 300	1000	300	23.0	300	26.0
Intermediate 400	1000	400	29.0	400	34.0
Corner LH/RH	1000	400	16.0	350	15.0
Side	1000	400	19.0	350	18.0



Trafficop Speed Cushions



Trafficop Speed Cushions with RediPave Splitter Islands



Unique Fixing
M10 x 120mm



Height (mm)	Gradient	Length (m)	Width (m)
65	1 in 10 ramp	2.0	1.6
	1 in 5 Side	3.0	1.7
		4.0	1.8
75	1 in 10 ramp	2.0	1.9
	1 in 4 side	3.0	1.6
		4.0	1.7
			1.8
			1.9

Please Note.
A 75mm cushion will use a 350mm corner section
A 65mm cushion will use a 400mm corner section

Trafficop Raised Tables

Trafficop Raised Tables offer a complete rubber option and are available with tapered sides or kerb options to suit the application.



Uxbridge



Cardiff



Cardiff



Trafficop Intermediate Module
300mm/400mm
wide x 1000mm long
75/65mm high

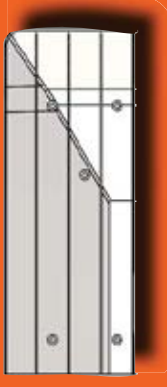

Trafficop Corner Module LH/RH
350mm/400mm
wide x 1000mm long
75/65mm high



Trafficop Ramp Module
300mm/400mm
wide x 1000mm long
75/65mm high



Trafficop Side Module
400mm
wide x 1000mm long
75/65mm high

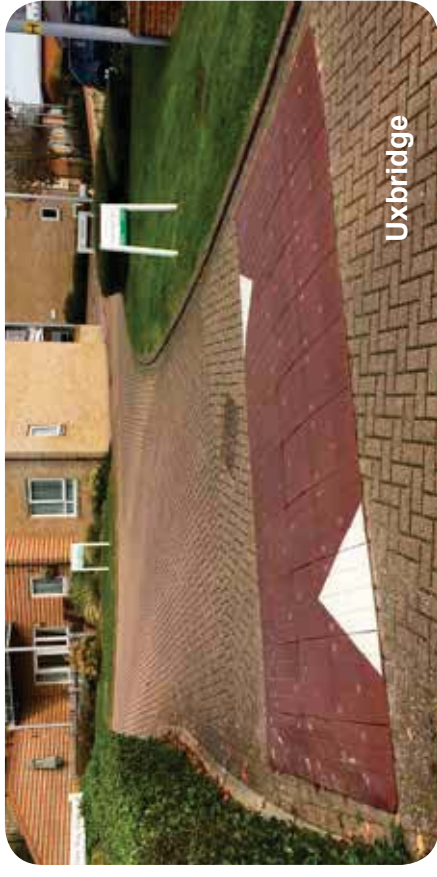

Uxbridge

Consistent

Consistent profile from preformed modules

No Excavation

No excavation and no spoil

Versatile

Different widths, lengths and heights, either kerb to kerb or tapered sides

Quiet

Energy absorbent reducing noise and vibrations

Environment

Recycled product made in the UK

Markings

High visibility markings moulded in at manufacture

Southampton



Wrexham



Stonengen,
Wiltshire



Combination Tables

Traficop Combination Construction offers cost effective solution with infill (by others) made of Dense Bitumen Macadam. This construction is ideal for junctions and pedestrian crossings.



Combination 1:16 75mm

- LH/RH Corner Module
350mm wide x 1000mm long
75mm high
15.0kg weight
- Ramp Module
400mm wide x 1000mm long
75mm high
26.0kg weight
- Side Module
350mm wide x 1000mm long
75mm high
18.0kg weight

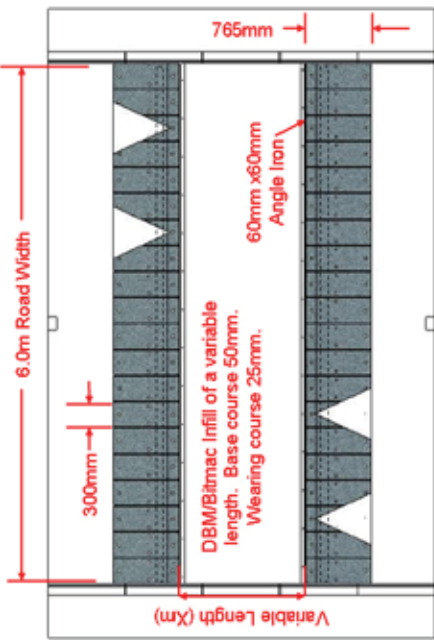

Combination 1:10 75mm

- LH/RH Corner Module
350mm wide x 1000mm long
75mm high
15.0kg weight
- Ramp Module
300mm wide x 765mm long
75mm high
13.0kg weight
- Side Module
350mm wide x 1000mm long
75mm high
18.0kg weight

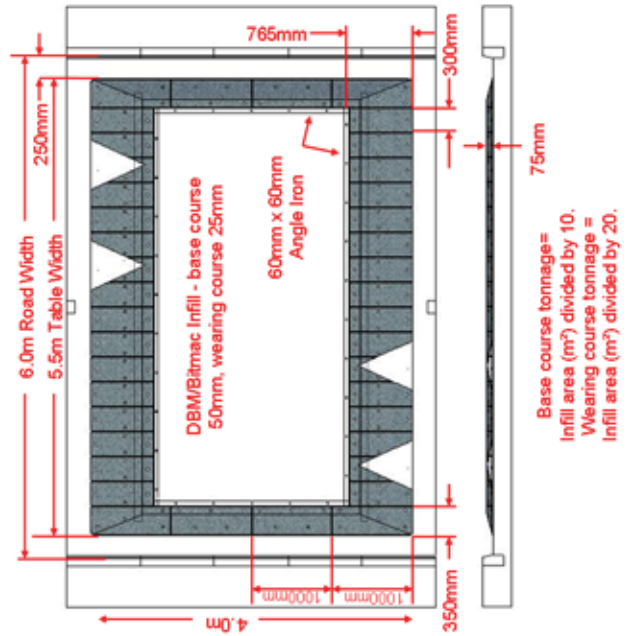

Neath Port Talbot

- Consistent**
Consistent profile from preformed modules
- No Excavation**
No excavation and no spoil
- Versatile**
Different widths, lengths and heights, either kerb to kerb or tapered sides
- Quiet**
Energy absorbent reducing noise and vibrations
- Environment**
Recycled product made in the UK
- Markings**
High visibility markings moulded in at manufacture

Passive Safety

TSRGD Highway Pole Cones
Jislon Highway Pole Cones offer durable solutions that can be installed quickly and last for a long time. Ø 80mm and height 1000mm (NS and NSE).

On Highway



London



M20, Kent

Crash friendly designed to rebound 1,000 times

Reducing the need of costly traffic management

Quick and easy to install

Improves safety at hazardous locations

Suitable for use in many applications

Rebound

Low Maintenance

Installation

High Visibility

Flexibility

Model	TSRGD NS	TSRGD NS	TSRGD NS	TSRGD NS	TSRGD NSE	TSRGD NSE
Colour	Orange (Special)	Orange	Orange or Black	Black (Wand)	Black (Wand)	Orange (Special)
Fixing	NS Type	NS Type	NS Type	NSE Type	NSE Type	NSE Type
Section	80mm	80mm	80mm	80mm	80mm	80mm
Above Ground	650mm	800mm	1000mm	1000mm	800mm	1000mm



Off Highway

Clapham Common,
London



Model	Off Highway Orange	Off Highway Orange/Yellow/Green/White	Off Highway Orange	Off Highway Orange	Off Highway Orange
Colour	Orange	Orange/Yellow/Green/White	Orange	Orange	Orange
Fixing	NS Type	NS Type	NS Type	NF Type	NF Type
Section	80mm	80mm	80mm	80mm	80mm
Above Ground	800mm	800mm	1000mm	1000mm	800mm



London



Dover

Passive Safety

Verge Markers



Model	Verge Marker	Verge Marker	Verge Marker	V-Flex Verge Marker
Colour	Black/White	Black/White	Black/White	Black/White
Fixing	NSE Type	NSE Type	NSE Type	Spike Anchor
Banding Options	Red/White	Amber/White	Amber/White	Red/White Amber/White
Section	80mm	80mm	80mm	100mm
Above Ground	800mm	800mm	800mm	1004mm



Durham



Aberystwyth



Passive Safety

Urban Pole Cones



Leicester



Greenwich



Model	City Pole Cone	City Pole Cone	City Pole Cone	City Pole Cone	City Pole Cone
Colour	Grey	Grey	Grey or Black	Yellow or Green	Grey or Black
Banding	White Red/ White Red	White Red/ White Red	Red/ White White Red	Red/ White White Red	Red/ White White Red
Fixing	NS Type	NS Type	NS Type	NS Type	NS Type
Section	80mm	80mm	130mm	130mm	130mm
Above Ground	800mm	800mm 900mm	800mm	800mm	1000mm

Model	2 Ring City Pole Cone	2 Ring City Pole Cone	Ball Top City Pole Cone	Ball Top City Pole Cone	Stainless Steel
Colour	Black	Black	Black	Black	Silver
Banding	Red/ White White	White Yellow	Red/ White White	Red/ White White	Red/White White
Fixing	NS Type	NS Type	NS Type	NS Type	NS Type
Section	130mm	130mm	80mm	80mm	80mm
Above Ground	650mm	1000mm	800mm	800mm	800mm

Fixings

Jision Pole Cones are available with a range of fixings;
 Embedded Anchor Ø 55mm NS Type
 Threaded Insert Ø 22mm NSE Type
 Surface Mounted NF Type



NS Type



NSE Type



NF Type

Pole Cone Caps

If you wish to unscrew your pole Cones for access then we offer the following caps



NSE Pole Cone Cap



NS Pole Cone Cap

Jision Signs Caps

Bespoke for 80mm Ø posts quick and easy to fit.



Installing an NSE Pole Cone



Installing an NS Pole Cone

Vehicle Stoppers

Rediweild Vehicle Stoppers offer a safe and effective way of protecting walkways as well as assets such as buildings, vehicles and equipment.

For heavy duty applications there are two versions TruckStop 150 (150mm high) for HGV's and TruckStop 115 (115mm high) for LGV's, Vans as well as coaches and buses.

For car parks, the 80mm high CarStop is ideal.

These products all have an asymmetric profile to prevent wheel trapping.

Easy Installation

Quick and easy to install and can be swiftly relocated

Safety Profile

Asymmetric profile for maximum resistance without wheel trapping

High Visibility

High visibility yellow markings moulded into the product

Environment

Recycled product made in the UK

TruckStop 150
300mm wide x 1000mm long
150mm high
25.0kg weight

TruckStop 115
220mm wide x 1000mm long
115mm high
15.0kg weight

CarStop
140mm wide x 1000mm long
80mm high
7.0kg weight



TruckStop 150



TruckStop 115



CarStop



TruckStop 150

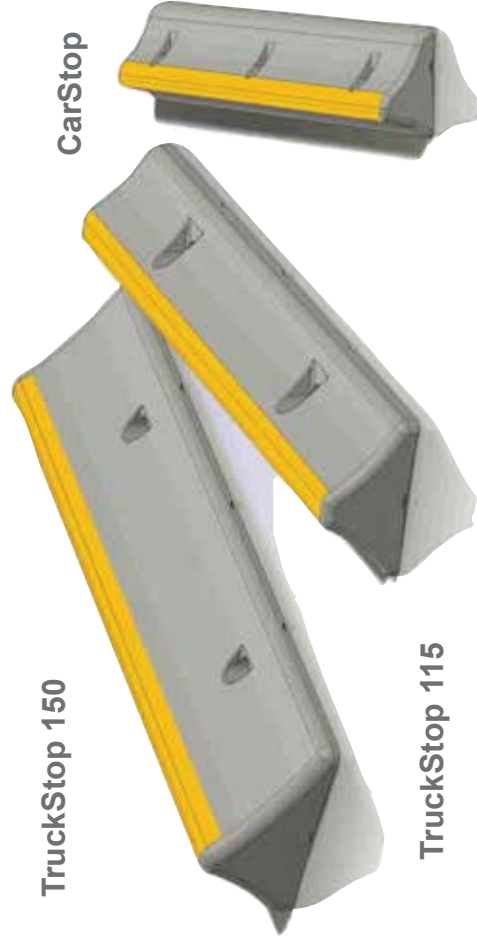

TruckStop 115

CarStop

TruckStop 150

TruckStop 150

TruckStop 150 is ideal for distribution and warehouse locations, as well as infrastructure sites such as ferry ports, overnight lorry parks.

The product provides protection with a heavy duty stopper to prevent damage to buildings, unloading bays and fences around a site.



Fixing
M16 x 120mm

Design Features

Innovative design to prevent vehicles or trailers from being trapped.

Manufactured from recycled rubber providing a tough product, safer on impact

Can be used as short or long lengths depending on application

Surface mounted minimising disruption with no spoil and reduced exposure to risk

To 'future proof' against changes in depots or distribution areas

High visibility yellow marking moulded in at time of manufacture

Fixing M16 x 120 for strength

Safety Benefits

Health & Safety

Easy Installation

Re-locatable

Markings

Fixing



TruckStop 115

Design Features

Innovative design to prevent vehicles from being trapped.

Safety Benefits

Manufactured from recycled rubber providing a tough product, safer on impact

Health & Safety

Can be used as short or long lengths depending on application

Easy Installation

Surface mounted minimising disruption with no spoil and reduced exposure to risk

Re-locatable

To 'future proof' against changes in depots, distribution areas, coach bays

Markings

High visibility yellow marking moulded in at time of manufacture

Fixing

Unique fixing M16 x 120 for strength

TruckStop 115

TruckStop 115 is a lower height to the TruckStop 150 so ideal for LGV size vehicles, like buses, coaches, vans, refrigeration lorries and tugs around a depot or distribution area where the higher version could catch under a trailer.

The product provides a barrier for these vehicles and protects walkways, buildings and fences around a site.

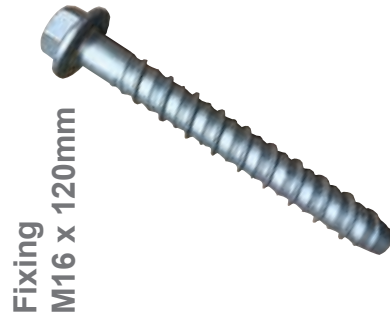

Fixing
M16 x 120mm

CarStop



Car Park, Guildford

CarStop

CarStop is ideal for applications such as car parks, charging points for electric cars, protecting walkways, retail or community areas and protecting buildings, walls or fences. They have also been used for providing a delineation for areas for forklifts in depots and distribution areas.

Design Features

Innovative design to prevent vehicles from being trapped.

Safety Benefits

Manufactured from recycled rubber providing a tough product, safer on impact

Health & Safety

Can be used as short or long lengths depending on application

Easy Installation

Surface mounted minimising disruption with no spoil and reduced exposure to risk

Re-locatable

To 'future proof' against changes in car parks, retail parks

Markings

High visibility yellow marking moulded in at time of manufacture

Fixing

Unique fixing Stainless Steel Coachscrew, rediplug & washer



Car Park, Jersey



Retail Park, Bridlington

Poole, Dorset

CarStop providing protection for electric charging points



**Unique Fixing
M10 x 120mm**

Sitecop Speed Ramps

Rediweid offers its unique Sitecop range of speed ramps with three different profiles to suit almost any application.

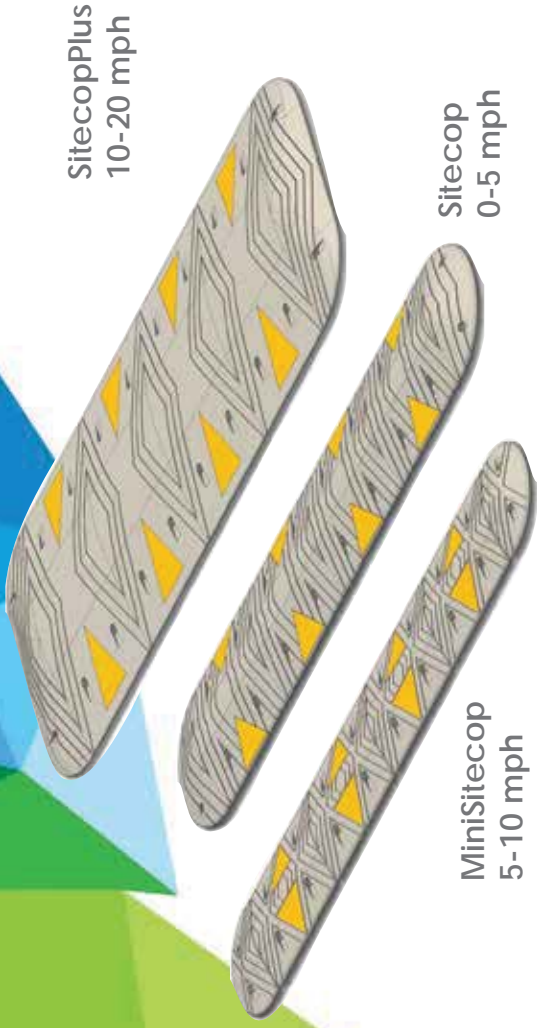

Excel Car Park, London



St Albans, Hertfordshire

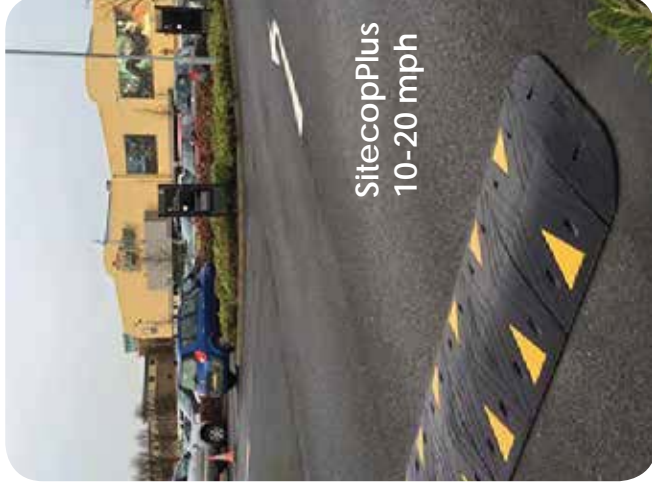

Easy Installation
Quick and easy to install and can be swiftly relocated

Quiet
'Soft' feel compared to other materials providing 'quiet' speed reduction

High Visibility
Distinctive high visibility yellow markings moulded into the product

Modular Design
Modular design with middle units 500mm wide and matching end units 250mm wide

Strength
For strength and alignment each style requires a reinforcing tube

Environment
Recycled product made in the UK

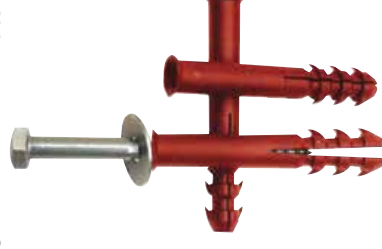

****Please note that a reinforcing tube is required for all Sitecop speed ramps. This is only supplied if Rediweid installs. MiniSitecop Ø 25mm and Sitecop/SitecopPlus Ø 50mm ****



MiniSitecop Middle

500mm wide x 400mm long
50mm high
6.5kg weight
4 Fixings

MiniSitecop End

250mm wide x 400mm long
50mm high
6.5kg weight
2 Fixings

MiniSitecop is the cost effective answer for reducing speeds in car parks, private roads and commercial areas.

Easy Installation

Quick and easy to install and can be swiftly relocated
'Soft' feel compared to other materials providing 'quiet' speed reduction

High Visibility

Distinctive high visibility yellow marking moulded in at time of manufacture

Modular Design

Modular design with middle units 500mm wide and matching end units 250mm wide

Strength

For strength and alignment each style requires a reinforcing tube

Environment

Recycled product made in the UK

Fixing

Unique fixing M10 x 120 for strength



Underground Car Park, Surrey



Granite effect, white markings
Maidenhead



Sitecop Middle

500mm wide x 500mm long
70mm high
12.5kg weight
4 Fixings

Sitecop End

250mm wide x 500mm long
70mm high
4.0kg weight
2 Fixings

The original **Sitecop** is ideal when severe speed reduction is needed for schools and access points or to prevent tailgating at barriers.



SitecopPlus Middle

500mm wide x 1000mm long
70mm high
25.0kg weight
4 Fixings

SitecopPlus End

250mm wide x 1000mm long
70mm high
8.0kg weight
2 Fixings

Designed to be less severe and suitable for HGV's, **SitecopPlus** is ideal for residential, retail, distribution and infrastructure sites.



Public Car Park, Luton



Housing complex, London



Docklands, London



Depot, Somerset

Tactile Surfaces

RediWeld offers a comprehensive range of tactile surfaces for the guidance of the visually impaired. Tiles are surface mounted with TakPave requiring adhesive and RediFix being mechanically fastened.

Buff



Red



Charcoal



Fastening Screw

Swindon



Installation of RediFix tiles

Keynsham



Hackney, London



DfT Guidance

Conforms with "Guidance on the use of Tactile Paving Surfaces"

Compliance

Assists providers to achieve DDA Compliance

Material

Unique mineral filled elastomers formulated for durability and abrasion resistance

Surface

Supplied in 400mm square tiles that can be adhered to most surfaces (TakPave) or mechanically fastened (RediFix)

Patterned

Cross hatched surface pattern for greater skid resistance

Colours

Available in buff, grey, black, blue, yellow and red (controlled crossing only)

London



Epping



TakPave

Pedestrian

Blister pattern
Indicates pedestrian crossing points

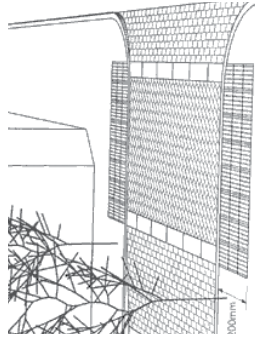

Corduroy

Ribbed pattern,
Indicates a hazard such as steps or ramps

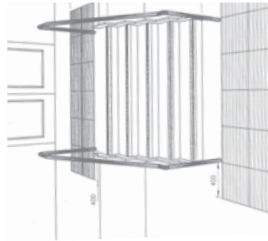

Cycle

Raised Bars
Indicates segregated shared cycle tracks/footpaths

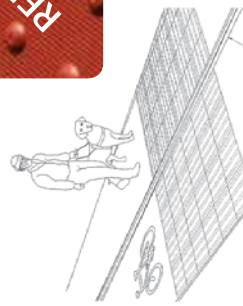

Dash

Raised bars
Provides a guidance path

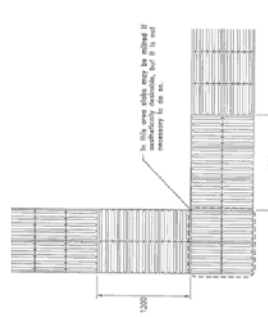

TakPave Corduroy
London



TakPave Pedestrian
Velodrome, London

Colours



* RED is only suitable for controlled crossings with Pedestrian Dot.



2 Part Adhesive for
TakPave

When installing TakPave and RediFix it is important to follow the information provided in the Department of Transport's Guidance on the use of Tactile Paving Surfaces[®]

BusPad Level Access Platform

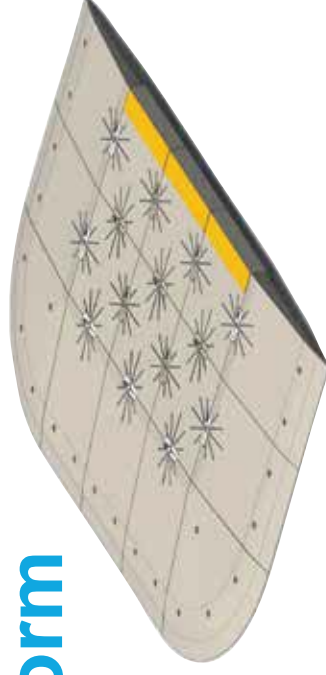

BusPad is a modular system that is quick to install and can vary in width and length to suit the location. A typical configuration is 3.5m long by 1.75m wide and a platform height of 65mm.

BusPad is supplied in Black complete with a yellow edge marking and white fixing blocks which outline the flat top area.

Easy Installation	Installed in less than 1 hour
DDA Conformance	Meet DDA Conformance on a budget
Ease of Maintenance	Long life expectancy
Minimum Disruption	To users and public
User friendly	Clearly marked and different feel under foot
Environment	Recycled product made in the UK

BusPad has been developed based on the experience and feedback of user groups. This resulted in features such as a fine leading edge to prevent a trip hazard, shallow ramp gradients and anti-slip surface on the ramps.



BusPad Corner Module
750mm wide x 750mm long
65mm high
15.0kg weight

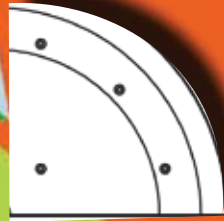

Dorset

BusPad Ramp Module
750mm wide x 500mm long
65mm high
16.0kg weight



Hertfordshire

BusPad Front Module
500mm wide x 500mm long
65mm high
18.0kg weight
(with yellow marking)



Carmarthenshire

BusPad Intermediate Module
500mm wide x 500mm long
65mm high
18.0kg weight



BusRamp Temporary Level Access Platform

BusRamp is a temporary modular system that is quick to install, provides a height of 130mm high and can be placed on areas where no existing pavements are located.

A typical configuration is 5.0mtr long by 2.0m wide and a platform height of 135mm.

The BusRamp is supplied in Black with a yellow edge marking and CarStops to prevent wheelchairs or pushchairs going off the end.

Easy Installation	Installed in less than 1 hour
Ease of Maintenance	Can be installed temporary to allow for easy removal.
Minimum Disruption	To users and public
User friendly	Clearly marked and different feel under foot
Environment	Recycled product made in the UK

BusRamp was created to offer raised platforms for events for wheel and pushchair access such as the Olympics in 2012. Since then we have provided this product for Park 'n' Ride locations, temporary Bus Stops in Car Parks and venues around the UK. The rubber modules are covered with a anti-slip boarding which offer a shallow ramp with a flat top area for ease of getting on and off buses or coaches, with stoppers to provide an edge. Can be installed loosely laid or fixed

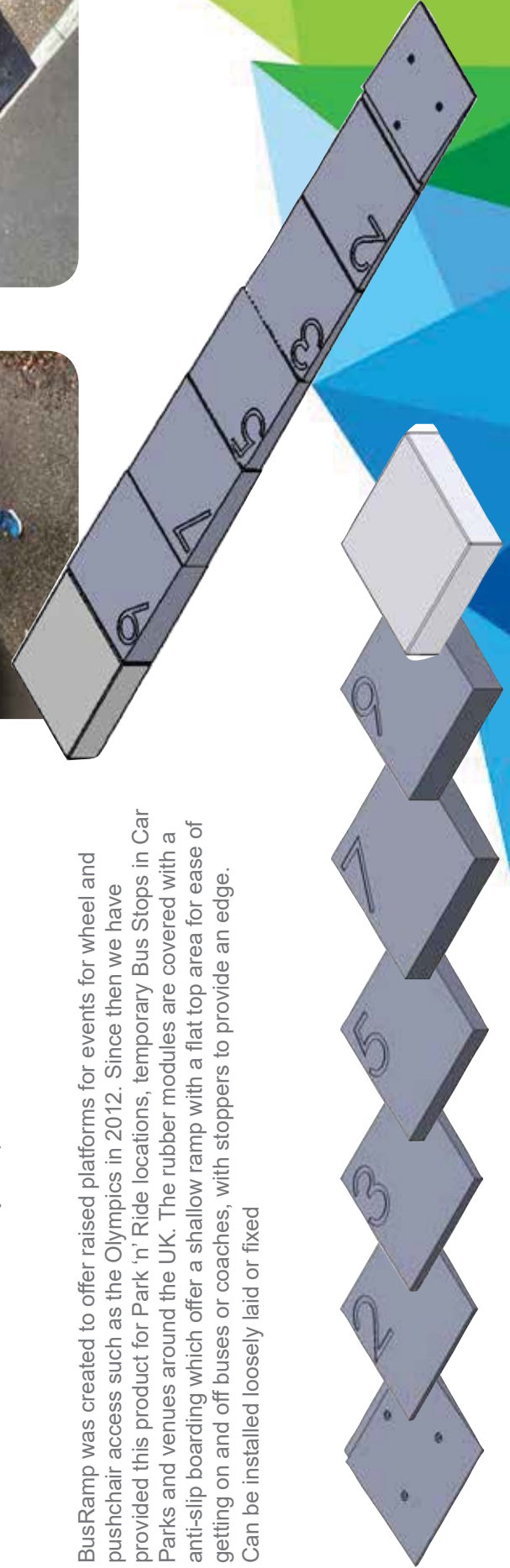

Installation and Support



Rediweld provides a contracting service that is a direct response to requests from local authorities and facility managers for products to be both supplied and installed from one source. Rediweld also offers support to contractors with installation training as well as site surveys and advice for new projects.

This service is offered across our range of products for traffic calming, islands and kerbing, level access, speed ramps, pole cones and tactile surfaces.

Rediweld carry out risk assessments and provide method statements and traffic management.

Rediweld offers maintenance packages for up to 5 years from the installation of the product which has been installed by Rediweld.

Customer Feedback: "Just a quick email to say thank you for making Accolades dealings with Rediweld run very smooth,

Your installation team carried out all that was asked of them and more, and made a great job of the installation in a very professional manner,

We will have no hesitation in dealing with Rediweld again in the future.

Accolade Wines



Trained

Qualified and experienced in-house installation team

Equipment

Fully resourced with appropriate plant & equipment

Chapter 8

'Give and Take' traffic management as per Chapter 8

Cost Effective

Fast, reliable and cost effective service

Site Surveys

Site survey and risk assessments carried out by trained staff

Site Supervision

Performed by trained staff, with good installation knowledge

Traffic Management

'Temporary Traffic Signals' or 'Stop and Go' can be arranged by Rediweld if required

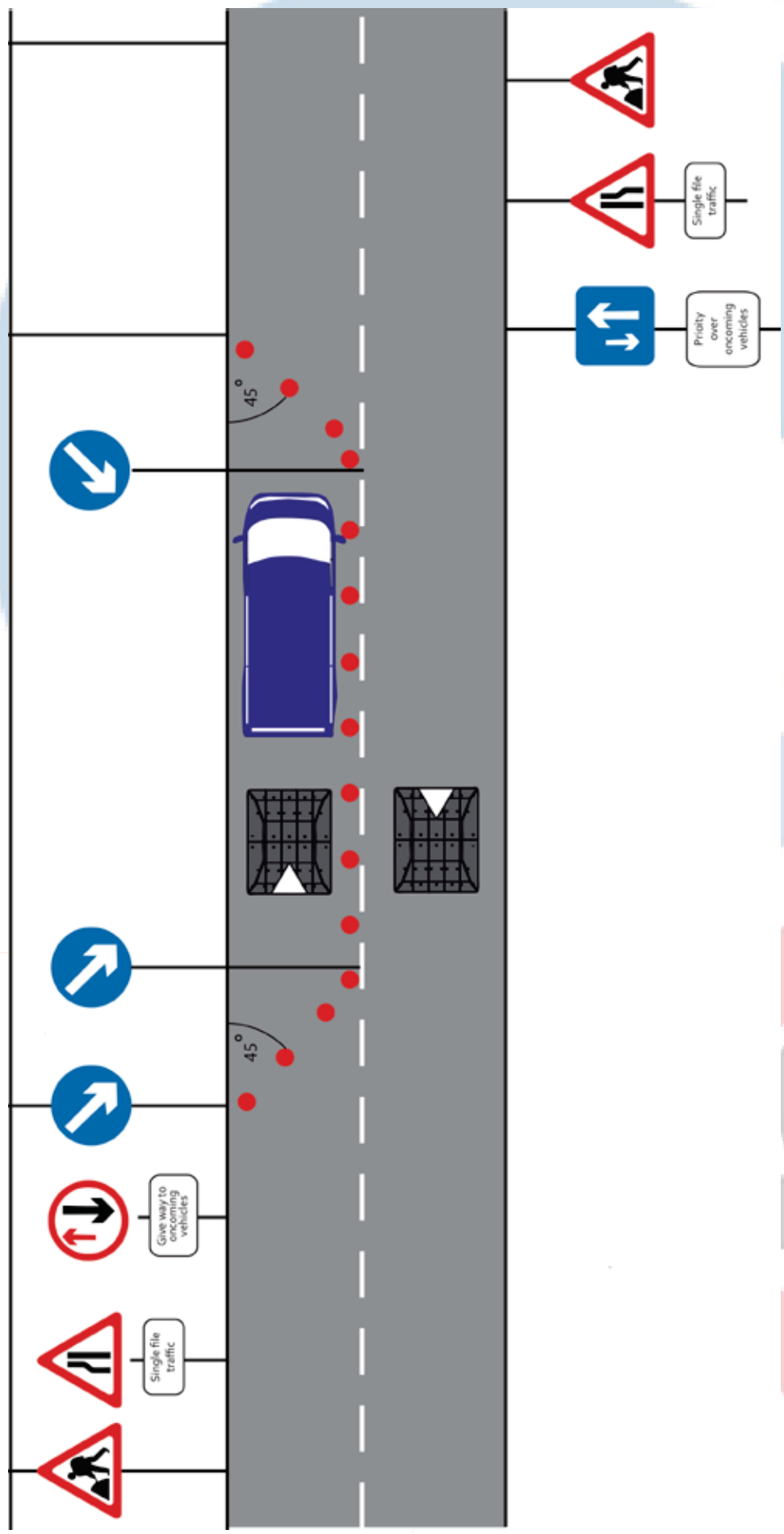

'Temporary Traffic Signals'



'Stop and Go' Boards



'Give and Take'



ABOUT US

Rediweld Traffic Products is a business unit of Rediweld Rubber and Plastics Ltd, which is a privately owned company.

The other business unit is Rediweld Technical Moulding which provides plastic and rubber moulding services for Aerospace and other technical sectors.

Put together Rediweld Rubber and Plastics offer a unique range of skills and processes for both Plastics and Rubber materials.



+44 1420 543007



www.rediweldtraffic.co.uk
traffic@rediweld.co.uk



Rediweld Traffic Products
6 - 10 Newnan Lane
Alton, Hampshire. GU34 2QR

